

ignion<sup>™</sup>

Your innovation.  
Accelerated.

# Mini antenna for Wi-Fi 6E

APPLICATION NOTE  
ONE mXTEND<sup>™</sup> (NN02-201)

## THE MINIATURE ONE mXTEND<sup>™</sup> FOR Wi-Fi 6E

- **Antenna Component:** ONE mXTEND<sup>™</sup> NN02-201
- **Dimensions:** 7.0 mm x 3.0 mm x 1.0 mm
- **Frequency regions:** 2.400-2.483 GHz, 5.170-5.835 GHz, and 5.925-7.125 GHz

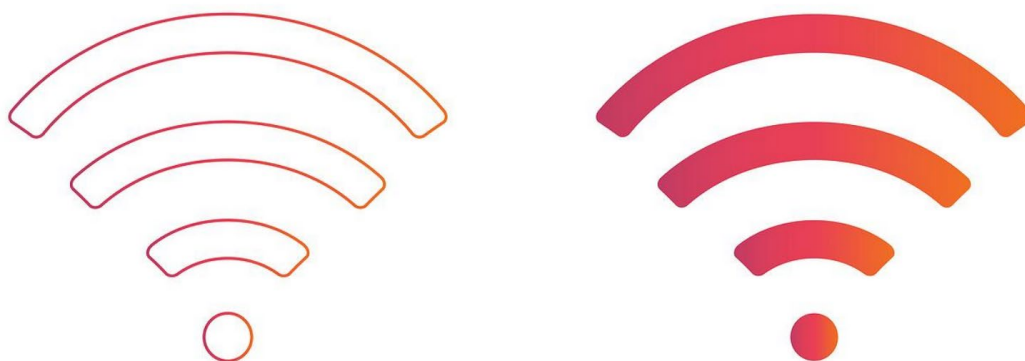

# Wi-Fi 6E

**Design your new Wi-Fi 6E device  
with a tiny, ultra-slim and standard chip antenna  
2.4 GHz + 5.0 GHz + 6.0 GHz**

Higher data rates, reduced spectrum congestion and more reliable connections are just a few of the advantages that Wi-Fi 6E technology has to offer. Most notably, the 6 GHz frequency band has been added to the already unlicensed spectrum in the 2.4 GHz and 5 GHz frequency ranges. This additional frequency band offers more bandwidth with more available channels to improve data speed rates, while preserving coverage and minimizing spectrum congestion in high density environments.

The Virtual Antenna<sup>®</sup> **ONE mXTEND<sup>™</sup>** antenna component can be easily tuned to any standard you need to support your requirements, now or in the future.

Thanks to its miniature size, only 7.0 x 3.0 x 1.0 mm, this tiny antenna booster fits in just about any platform. Its tiny volume is **only 21mm<sup>3</sup>**. On top of this, the ONE mXTEND<sup>™</sup> antenna will enable you to design products in the smallest of form factors according to your needs, it will be **faster, easier, and cheaper** than ever before.

\* Please note that the ONE mXTEND<sup>™</sup> is a versatile antenna solution that is able to cover other frequency ranges besides those covered in this document. If your device is to operate in any other band, please contact to [support@ignion.io](mailto:support@ignion.io) for assistance.

## TABLE OF CONTENTS

<b>1. PRODUCT DESCRIPTION NN02-201</b>	<b>4</b>
<b>2. ELECTRICAL PERFORMANCE</b>	<b>5</b>
<b>2.1. QUICK REFERENCE GUIDE</b>	<b>5</b>
<b>2.2. EVALUATION BOARD FOR Wi-Fi 6E</b>	<b>6</b>
<b>2.3. VSWR AND TOTAL EFFICIENCY</b>	<b>7</b>
<b>2.4. MATCHING NETWORK</b>	<b>8</b>
<b>2.5. RECOMMENDED ANTENNA FOOTPRINT FOR NN02-201</b>	<b>9</b>
<b>2.6. RADIATION PATTERNS (2.400 – 2.483 GHz, 5.125 – 5.835 GHz and 5.925 – 7.125 GHz), GAIN, AND EFFICIENCY</b>	<b>10</b>
<b>3. PERFORMANCE vs EVALUATION BOARD SIZE</b>	<b>12</b>
<b>3.1. EVALUATION BOARD</b>	<b>12</b>
<b>3.2. VSWR AND EFFICIENCY</b>	<b>13</b>
<b>3.3. MATCHING NETWORK</b>	<b>14</b>
<b>3.4. RADIATION PATTERNS (2.400 - 2.500 GHz), GAIN, AND EFFICIENCY</b>	<b>16</b>
<b>3.5. RADIATION PATTERNS (5.170 - 5.835 GHz), GAIN, AND EFFICIENCY</b>	<b>18</b>
<b>3.6. RADIATION PATTERNS (5.925 - 7.125 GHz), GAIN, AND EFFICIENCY</b>	<b>20</b>

## 1. PRODUCT DESCRIPTION NN02-201

The ONE mXTEND<sup>™</sup>, a multi-band miniature antenna booster, is capable of easy adaption to just about any kind of device. Featuring an extremely small package that requires only a nominal space, the ONE mXTEND<sup>™</sup> is a versatile product capable of operating in all the Wi-Fi 6E frequency bands through the same single antenna package.

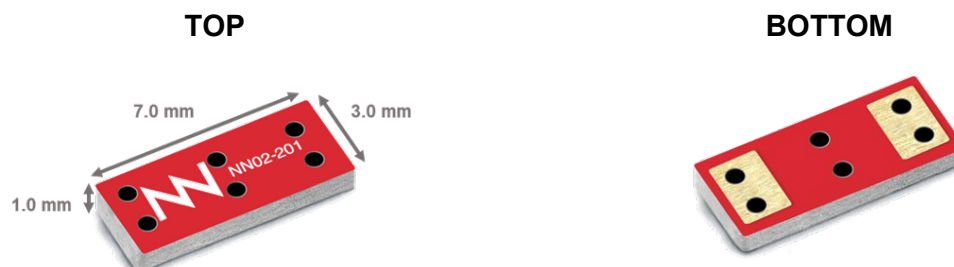

**Material:** The ONE mXTEND<sup>™</sup> antenna booster is built on glass epoxy substrate.

### APPLICATIONS

- Routers and Gateways
- Modules
- Asset Tracking
- IoT Sensors
- Handsets and smartphones
- Tablets and PCs
- Digital cameras

### BENEFITS

- Multiband
- High efficiency
- Small size
- Cost-effective
- Easy-to-use (pick and place)
- Off-the-Shelf standard product (no customization required)

The ONE mXTEND<sup>™</sup> antenna booster belongs to a new generation of antenna solutions based upon our Virtual Antenna<sup>®</sup> technology. This technology replaces conventional and custom antenna solutions with a new class of antenna boosters, delivered in the form of a new range of miniature and off-the-shelf chip antenna components. These new chip antennas are multiband and multipurpose. They fit in a variety of wireless platforms to provide a wireless link at plenty of different communication services. By using a Virtual Antenna<sup>®</sup> component the design becomes more predictable compared to a custom solution, making the whole process **faster, cost effective and easier.**

## 2. ELECTRICAL PERFORMANCE

### 2.1. QUICK REFERENCE GUIDE

Technical features	2.400 – 2.483 GHz	5.170 – 5.835 GHz	5.925 – 7.125 GHz
Average Efficiency	> 65%	> 80%	>70%
Peak Gain	4.85 dBi	5.6 dBi	6.6 dBi
VSWR	< 3.0:1	< 2.0:1	< 2.0:1
Radiation Pattern	Omnidirectional		
Polarization	Linear		
Weight (approx.)	0.02 g.		
Temperature	-40 to + 125 °C		
Impedance	50 Ω		
Dimensions (L x W x H)	7.0 mm x 3.0 mm x 1.0 mm		

## 2.2. EVALUATION BOARD FOR Wi-Fi 6E

The Evaluation Board EB-NN02-201-WiFi6E integrates the ONE mXTEND<sup>™</sup> antenna booster to provide operation in the frequency region going from 2.400 GHz to 2.483 GHz, 5.125 GHz to 5.835 GHz and 5.925 GHz to 7.125 GHz, through a single input/output port.

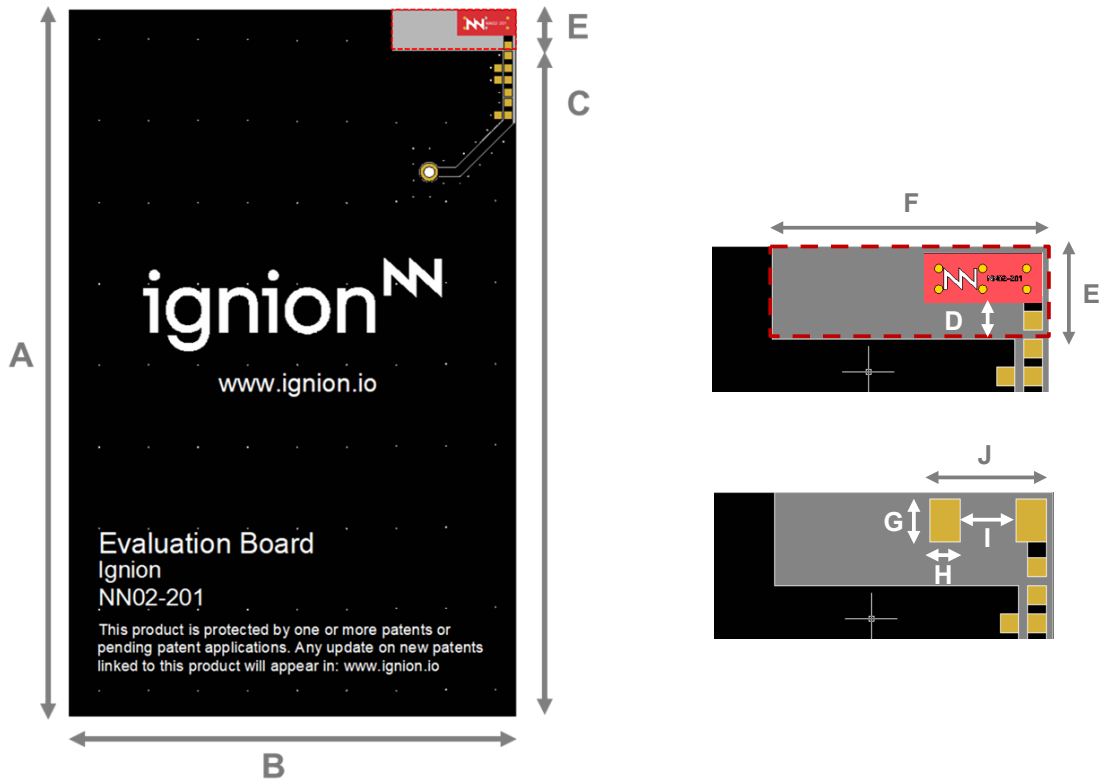

Measure	mm	Measure	mm
A	86	F	15
B	54	G	2.3
C	81	H	1.65
D	2.0	I	3.0
E	5.0	J	6.3

**Tolerance:** ±0.2 mm

**D:** Distance between the ONE mXTEND<sup>™</sup> antenna booster and the ground plane.

**Material:** The evaluation board is built on FR4 substrate. Thickness is 1 mm.

**Clearance Area:** 15 mm x 5.0 mm (FxE) (indicated in dashed red line)

**Figure 1** – Evaluation board dimensions.

## 2.3 VSWR AND TOTAL EFFICIENCY

This section explains the antenna performance in terms of VSWR (Voltage Standing Wave Ratio) and Total Efficiency results versus frequency (GHz) for the Wi-Fi 6E frequency bands.

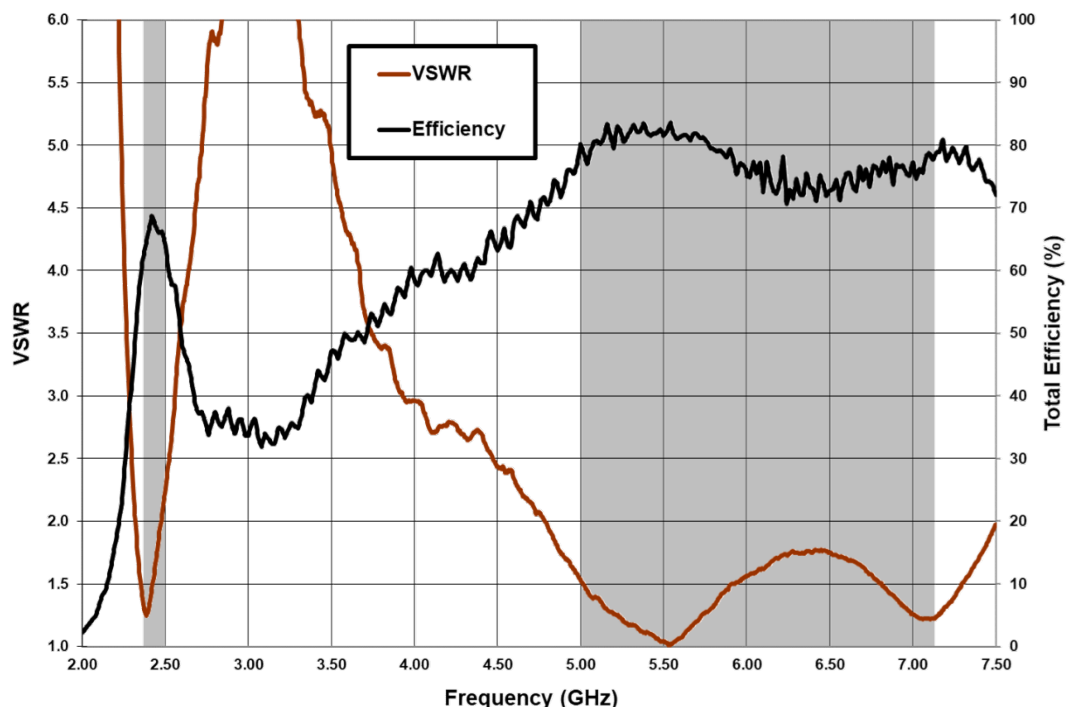

**Figure 2** – VSWR and Total Efficiency for the 2.400 – 2.483 GHz frequency range and for the 5.170 – 7.125 GHz frequency from the evaluation board (Figure 1).

ONE mXTEND<sup>™</sup> operates in the required Wi-Fi 6E frequency spectrum with high efficiency values. Please note that its high performance can be maintained across different PCB sizes by simply adjusting the matching network design.

## 2.4. MATCHING NETWORK

The ONE mXTEND<sup>™</sup> antenna booster needs a matching network to connect to your Wi-Fi 6E transceiver. This section describes the recommended matching network topology and component values (Figure 3) from the Evaluation Board (Figure 1).

Thanks to its versatility, the ONE mXTEND<sup>™</sup> antenna booster can easily be tuned to cover the Wi-Fi spectrum through simply adjusting the matching network. The excellent tuning possibilities of the ONE mXTEND<sup>™</sup> make it ideal for avoiding unnecessary and time-consuming product redesigns each time your product specifications and operating frequencies vary. It allows you to easily adapt your design to different applications, market segments, and devices whilst maintaining the same antenna by simply adjusting the design of the matching network.

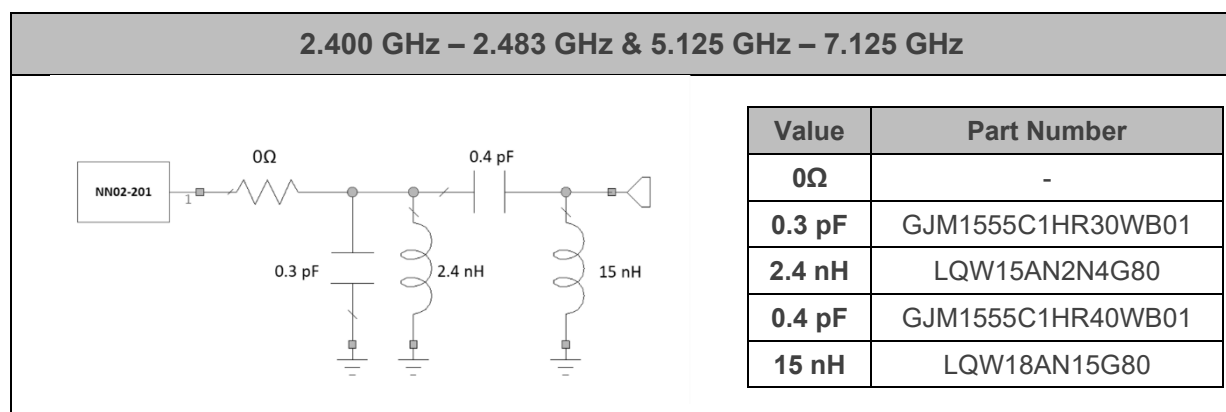

**Figure 3** – Topology and values of the matching network from the evaluation board (Figure 1).

The antenna performance is always conditioned by its operating environment. Different devices with different printed circuit board sizes, components nearby the antenna, LCD's, batteries, covers, connectors, etc. may need a different matching network. Accordingly, it is highly recommended to place pads compatible with 0402 and 0603 SMD components for a matching network as close as possible to the feeding point of the antenna element in the ground plane area, not in the clearance area. This provides a degree of freedom to tune the ONE mXTEND<sup>™</sup> antenna booster once the design is finished and takes into account all elements of the system (batteries, displays, covers, etc.). To ensure optimal results, the use of high-quality factor (Q) and tight tolerance components is highly recommended (e.g. Murata components (**Figure 3**)).

If you need assistance to design your matching network beyond this application note, please contact at [support@ignion.io](mailto:support@ignion.io), or if you are designing a **different device size** or a **different frequency band**, we can assist you in less than 24 hours. Please, try our free-of-charge<sup>1</sup> **Antenna Intelligence Cloud** design service (<https://ignion.io/antenna-intelligence/>), you will get your complete design report including a custom matching network for your device in 24h<sup>1</sup>. Additional information related to Ignion's range of R&D services is available at: <https://ignion.io/rdservices/>

<sup>1</sup> See terms and conditions for a free Antenna Intelligence Cloud service in 24h at: <https://www.ignion.io/antenna-intelligence/>



## 2.5. RECOMMENDED ANTENNA FOOTPRINT FOR NN02-201

The ONE mXTEND<sup>™</sup> antenna booster (NN02-201) must be placed as close as possible to a corner of the PCB. See below the recommended footprint dimensions when it is placed close to a corner of the PCB with the feeding line aligned with the longest side of the board according to the Evaluation Board (Figure 1).

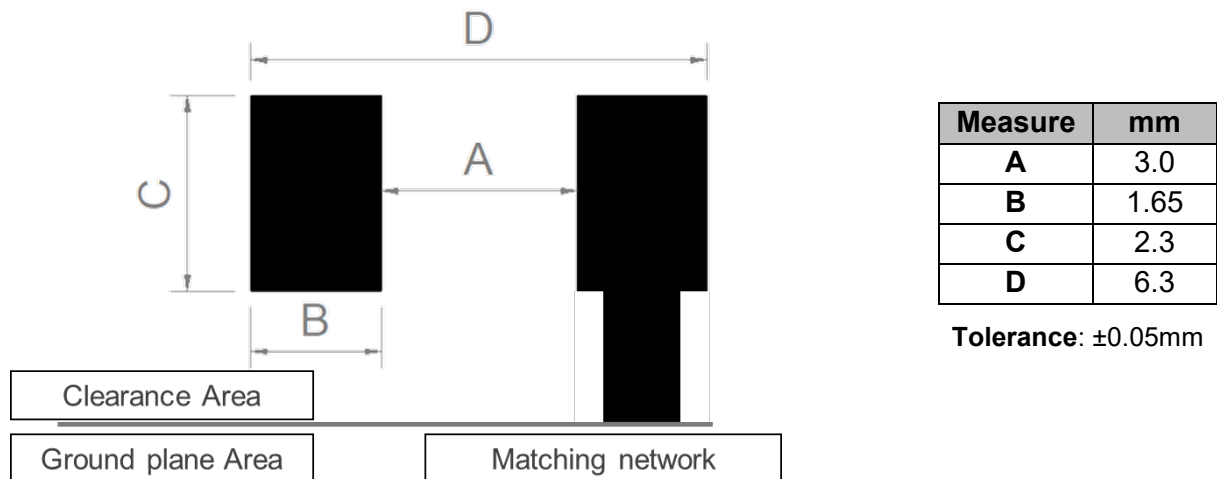

**Figure 4** - Footprint dimensions for the ONE mXTEND<sup>™</sup> (NN02-201) antenna booster.

## 2.6. RADIATION PATTERNS (2.400 – 2.483 GHz, 5.125 – 5.835 GHz and 5.925 – 7.125 GHz), GAIN, AND EFFICIENCY

This section describes the different radiation patterns, gain and efficiency of the ONE mXTEND<sup>™</sup> antenna booster for Wi-Fi 6E.

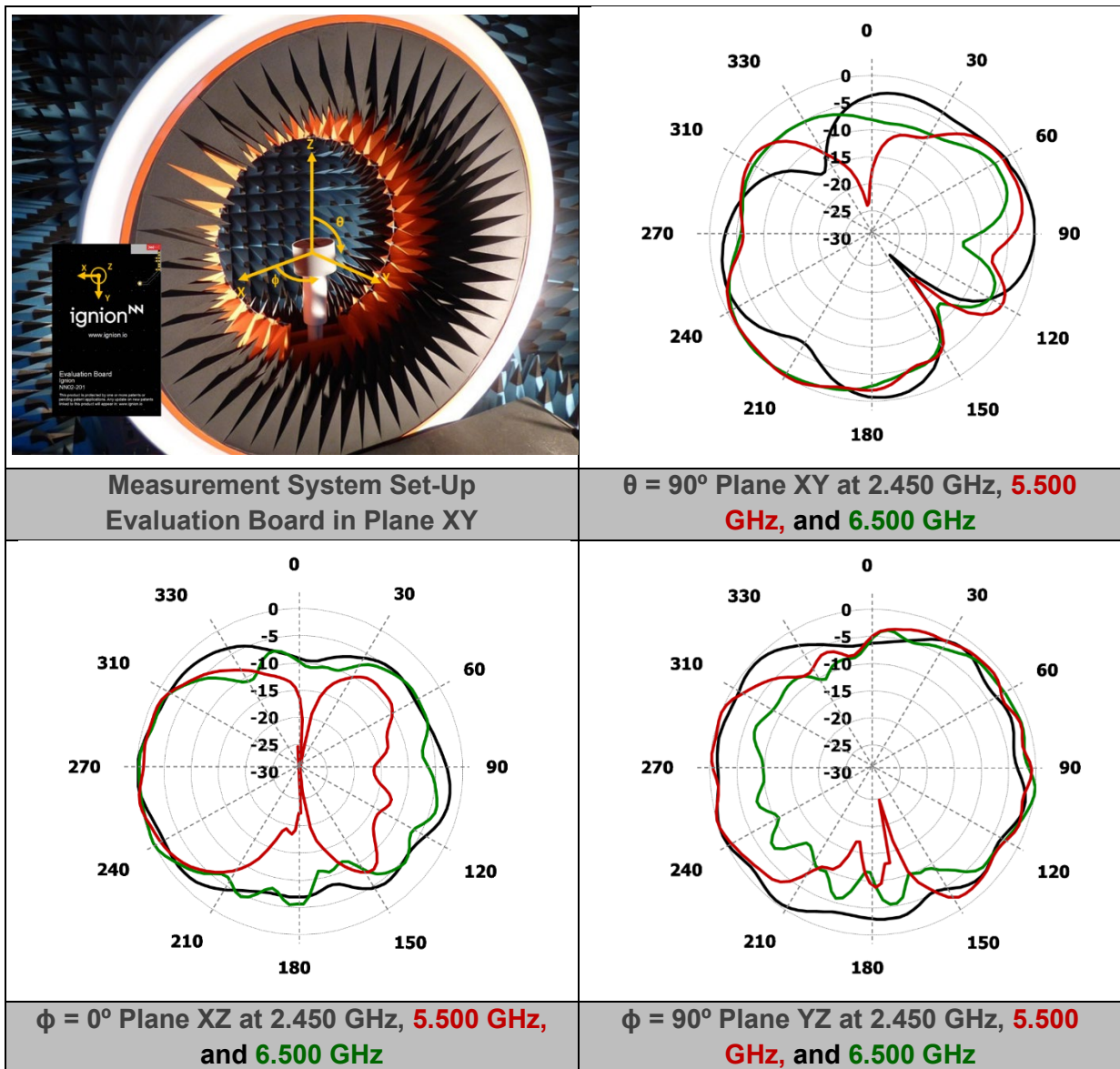

<b>LFR Wi-Fi 6E 2.400-483 GHz</b>	<b>Gain</b>	<b>Peak Gain</b>	2.7 dBi
		<b>Average Gain across the band</b>	2.4 dBi
		<b>Gain Range across the band (min, max)</b>	2.2 <--> 2.7 dBi
	<b>Efficiency</b>	<b>Peak Efficiency</b>	67.8 %
		<b>Average Efficiency across the band</b>	66.6 %
		<b>Efficiency Range across the band (min, max)</b>	63.8 – 67.8 %

**Table 1** - Antenna gain and total efficiency from the Evaluation Board (Figure 1) for 2.400GHz – 2.483GHz with the matching network of Figure 3.

<b>HFR Wi-Fi 6E 5.170-5.835 GHz</b>	<b>Gain</b>	<b>Peak Gain</b>	3.6 dBi
		<b>Average Gain across the band</b>	3.3 dBi
		<b>Gain Range across the band (min, max)</b>	3.2 – 3.6 dBi
	<b>Efficiency</b>	<b>Peak Efficiency</b>	83.6 %
		<b>Average Efficiency across the band</b>	81.5 %
		<b>Efficiency Range across the band (min, max)</b>	79.0 – 83.6 %

**Table 2** - Antenna gain and total efficiency from the Evaluation Board (Figure 1) for 5.170 GHz – 5.835 GHz with the matching network of Figure 3.

<b>HFR Wi-Fi 6E 5.925-7.125 GHz</b>	<b>Gain</b>	<b>Peak Gain</b>	4.6 dBi
		<b>Average Gain across the band</b>	3.4 dBi
		<b>Gain Range across the band (min, max)</b>	2.6 – 4.6 dBi
	<b>Efficiency</b>	<b>Peak Efficiency</b>	78.7 %
		<b>Average Efficiency across the band</b>	75.0 %
		<b>Efficiency Range across the band (min, max)</b>	70.7 – 78.7 %

**Table 3** – Antenna gain and total efficiency from the Evaluation Board (Figure 1) for 5.925 GHz – 7.125 GHz with the matching network of Figure 3.

### 3. PERFORMANCE vs EVALUATION BOARD SIZE

#### 3.1. EVALUATION BOARD

The performance of the ONE mXTEND<sup>™</sup> antenna booster operating in the Wi-Fi 6E frequency bands is measured in different evaluation boards sizes. This section is intended to illustrate on one hand, how the antenna performance varies according to the ground plane length of any printed circuit board (PCB), and on the other hand, how our ONE mXTEND<sup>™</sup> antenna booster can be easily adapted to the different scenarios by simply adjusting the matching network design. The antenna part remains the same and the operating frequencies can be easily tuned by adjusting the matching network. The following results cover a wide scope of EB sizes (length and width), ranging from 200 mm x 200 mm down to 86 mm x 54 mm (Figure 5), representatives of routers, gateways, smartphones, and small tracker or IoT devices.

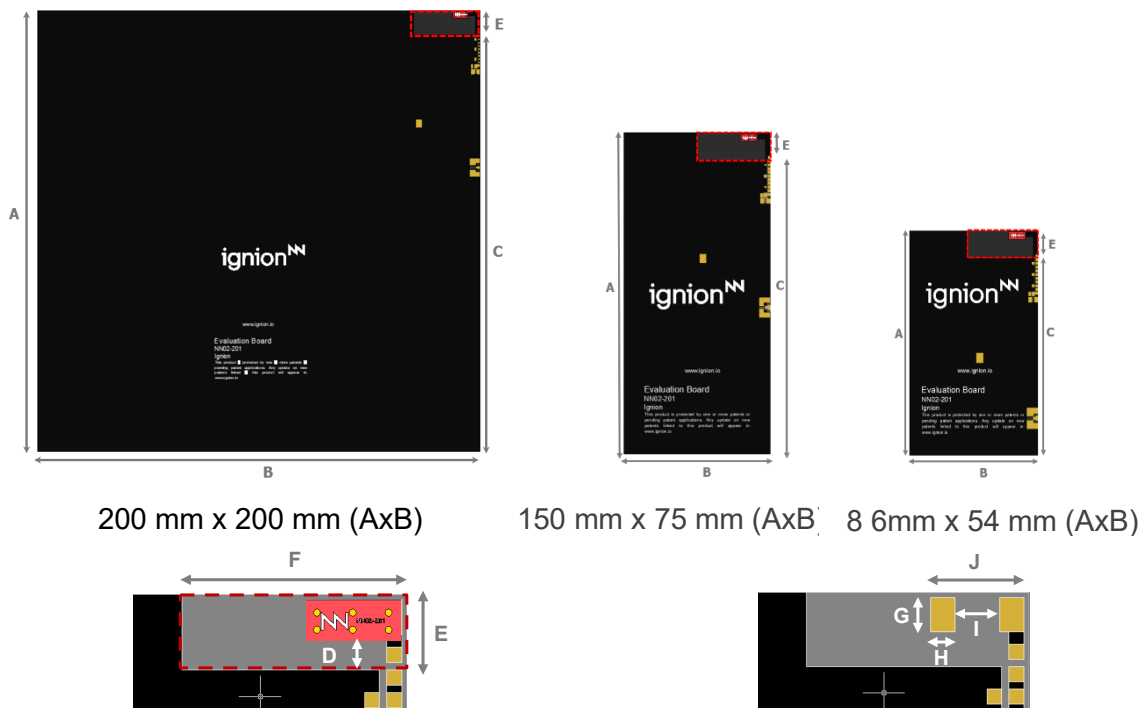

Measure	mm	Measure	mm
A	200 – 86	F	15
B	200 – 54	G	2.3
C	195 – 81	H	1.65
D	2.0	I	3.0
E	5.0	J	6.3

**Tolerance:** ±0.2 mm

**D:** Distance between the ONE mXTEND<sup>™</sup> antenna booster and the ground plane.

**Material:** The evaluation board is built on FR4 substrate. Thickness is 1 mm.

**Clearance Area:** 15 mm x 5.0 mm (FxEx) (indicated in dashed red line)

**Figure 5** – Evaluation boards with different form factors and different ground plane lengths. Detailed image of the ONE mXTEND<sup>™</sup> antenna booster placed in the top right corner of the different sized EBs (left) and its footprint (right).

Please note that the ONE mXTEND™ is a versatile antenna solution that is able to cover other frequency ranges besides those covered in this document. If your device is to operate in any other band, please contact to [support@ignion.io](mailto:support@ignion.io) for assistance. We are here to help.

### 3.2. VSWR AND EFFICIENCY

This section explains the antenna performance in terms of VSWR (Voltage Standing Wave Ratio) and Total Efficiency results versus frequency (GHz) for the Wi-Fi 6E frequency bands.

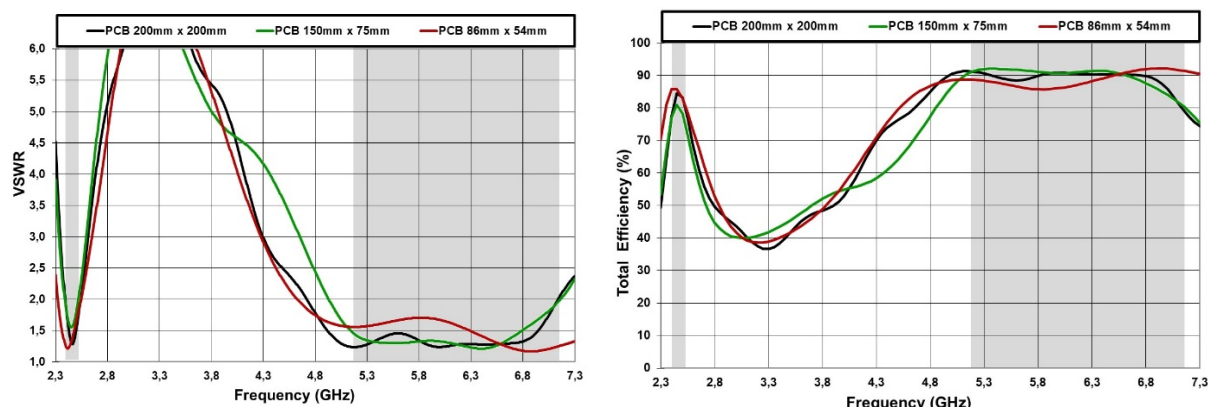

**Figure 6** – VSWR and Total Efficiency for the 2.400 – 2.500 GHz frequency range and for the 5.170 – 7.125 GHz frequency range considering the different EB sizes (Figure 5).

2.400 – 2.500 GHz					
B x C (mm)	$\eta_a$ 2400 MHz	$\eta_a$ 2500 MHz	Min	Max	Av. $\eta_a$
200 x 200	77.6	83.3	77.6	84.6	81.8
150 x 75	77.2	78.3	77.2	81.8	78.9
86 x 54	85.8	83.0	83.0	85.9	84.9

**Table 4** – Antenna efficiency comparison considering the different EB sizes for 2.400 – 2.500GHz frequency range (Figure 5).

B x C (mm)	5.170 – 5.835 GHz					5.925 – 7.125 GHz				
	$\eta_a$ 5170MHz	$\eta_a$ 5835MHz	Min	Max	Av. $\eta_a$	$\eta_a$ 5925MHz	$\eta_a$ 7125MHz	Min	Max	Av. $\eta_a$
200 x 200	91.3	90.3	88.5	91.3	89.7	90.6	79.3	79.3	90.9	89.0
150 x 75	90.7	91.0	90.7	92.1	91.6	90.9	80.5	80.5	91.5	88.7
86 x 54	88.8	85.8	85.8	88.8	87.3	85.8	91.5	85.8	92.2	89.6

**Table 5** - Antenna efficiency comparison considering the different EB sizes for 5.170 - 5.835 GHz and 5.925 – 7.125 GHz frequency ranges (Figure 5).

ONE mXTEND™ operates the required Wi-Fi 6E frequency spectrum with high efficiency values. Please note that its performance can be maintained high across different sized EBs by simply adjusting the matching network design.

### 3.3. MATCHING NETWORK

The ONE mXTEND™ antenna booster needs a matching network to connect to your Wi-Fi 6E transceiver. This section describes the recommended matching network topologies and values (Figure 7, Figure 8, Table 6 and Table 7) for the different sized EBs (Figure 5).

Thanks to its versatility the ONE mXTEND™ antenna booster can be easily tuned to cover Wi-Fi 6E spectrum in different sized platforms through just the proper adjustment of the matching network. The excellent tuning capabilities of the ONE mXTEND™ makes it ideal to avoid unnecessary product redesigns each time your product specifications and operating frequencies vary. It allows you to easily adapt your design to different applications, market segments, and devices through the proper design of the matching network by maintaining the same antenna part.

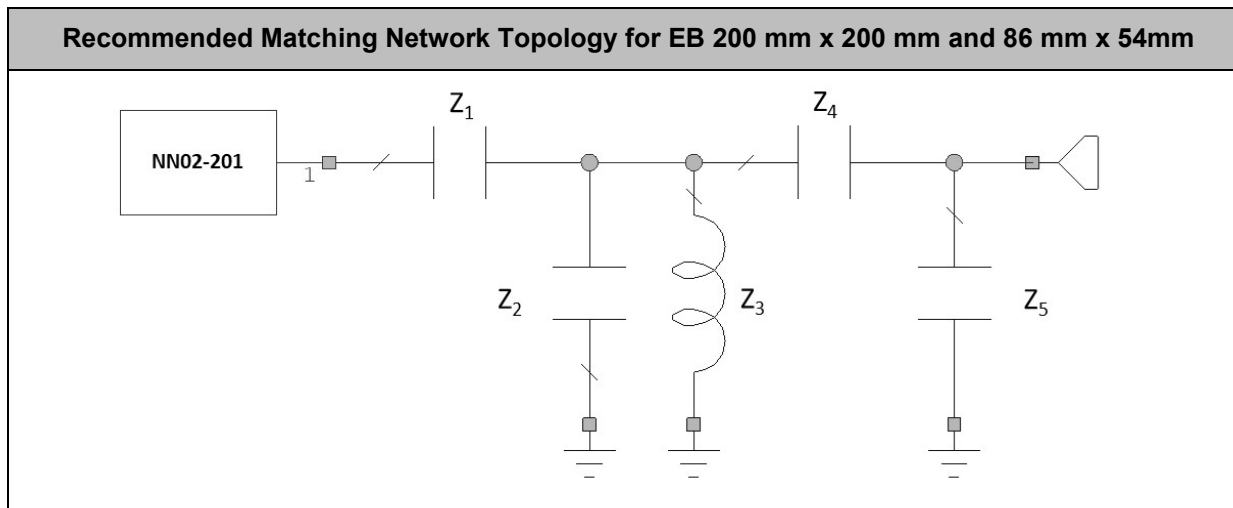

**Figure 7** – Topology of the matching network mounted at the solutions: 200 mm x 200 mm and 86 mm x 54 mm (Figure 5).

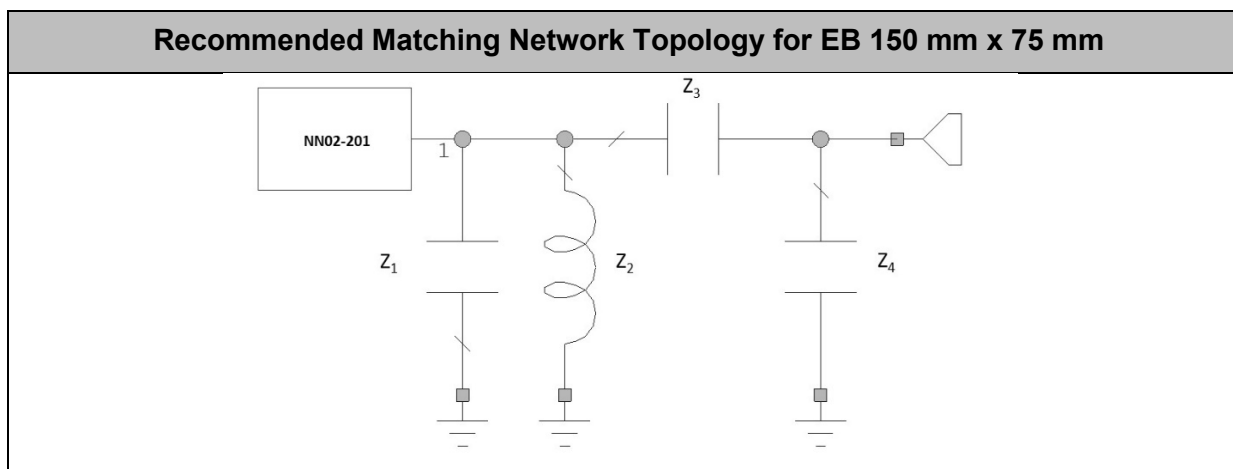

**Figure 8** - Topology of the matching network mounted at the solution: 150 mm x 75 mm (Figure 5).

The matching network topology (Figure 7) remains equal for the cases 200 mm x 200 mm and 86 mm x 54 mm and just the values of the matching network components must be adjusted to tune the antenna performance to the required operating frequency bands. A different matching network topology is recommended for the 150 mm x 75 mm case (Figure 8). The recommended matching network component values for operating the Wi-Fi 6E standards ranging from 2.400 – 2.500 GHz and 5.170 – 7.125 GHz are shown in Table 6 and Table 7.

A x B (mm)	Z <sub>1</sub>	Z <sub>2</sub>	Z <sub>3</sub>	Z <sub>4</sub>	Z <sub>5</sub>
200 mm x 200 mm	4.0pF	0.3pF	2.3nH	0.4pF	0.3pF
150 mm x 75 mm	0.3pF	2.6nH	0.4pF	0.3pF	-
86 mm x 54 mm	2.4pF	0.2pF	2.7nH	0.4pF	0.2pF

**Table 6** - Values of the matching network components for the different EB sizes (Figure 5).

Value		Part Number
Z1	4.0pF	GJM1555C1H4R0WB01
	0.3pF	GJM1555C1HR30WB01
	2.4pF	GJM1555C1H2R4WB01
Z2	0.3pF	GJM1555C1HR30WB01
	2.6nH	LQW15AN2N6G80
	0.2pF	GJM1555C1HR20WB01
Z3	2.3nH	LQW15AN2N3G80
	0.4pF	GJM1555C1HR40WB01
	2.7nH	LQW15AN2N7G80
Z4	0.4pF	GJM1555C1HR40WB01
	0.3pF	GJM1555C1HR30WB01
	0.4pF	GJM1555C1HR40WB01
Z5	0.3pF	GJM1555C1HR30WB01
	0.2pF	GJM1555C1HR20WB01

**Table 7** - Values and part numbers of the components used for the matching networks for the different EB sizes.

The antenna performance is always conditioned by its operating environment. Different devices with different printed circuit board sizes, components nearby the antenna, LCD's, batteries, covers, connectors, etc. may need a different matching network. Accordingly, it is highly recommended placing pads compatible with 0402 and 0603 SMD components for a matching network as close as possible to the feeding point of the antenna element in the ground plane area, not in the clearance area. This provides a degree of freedom to tune the ONE mXTEND™ antenna booster once the design is finished and takes into account all elements of the system (batteries, displays, covers, etc.). To ensure optimal results, the use of high-quality factor (Q) and tight tolerance components is highly recommended (e.g. Murata components (Table 6 and Table 7)).

If you need assistance to design your matching network beyond this application note, please contact [support@ignion.io](mailto:support@ignion.io), or if you are designing a **different device size** or a **different frequency band**, we can assist you in less than 24 hours. Please, try our free-of-charge<sup>1</sup> [Antenna Intelligence Cloud](#), which will get you a complete design report including a custom matching network for your device in 24h<sup>2</sup>. Additional information related to NN's range of R&D services is available at: <https://ignion.io/rdservices/>

### 3.4. RADIATION PATTERNS (2.400 - 2.500 GHz), GAIN, AND EFFICIENCY

This section describes the different radiation patterns, gain and efficiency of the ONE mXTEND™ antenna booster depending on the different evaluation board sizes.

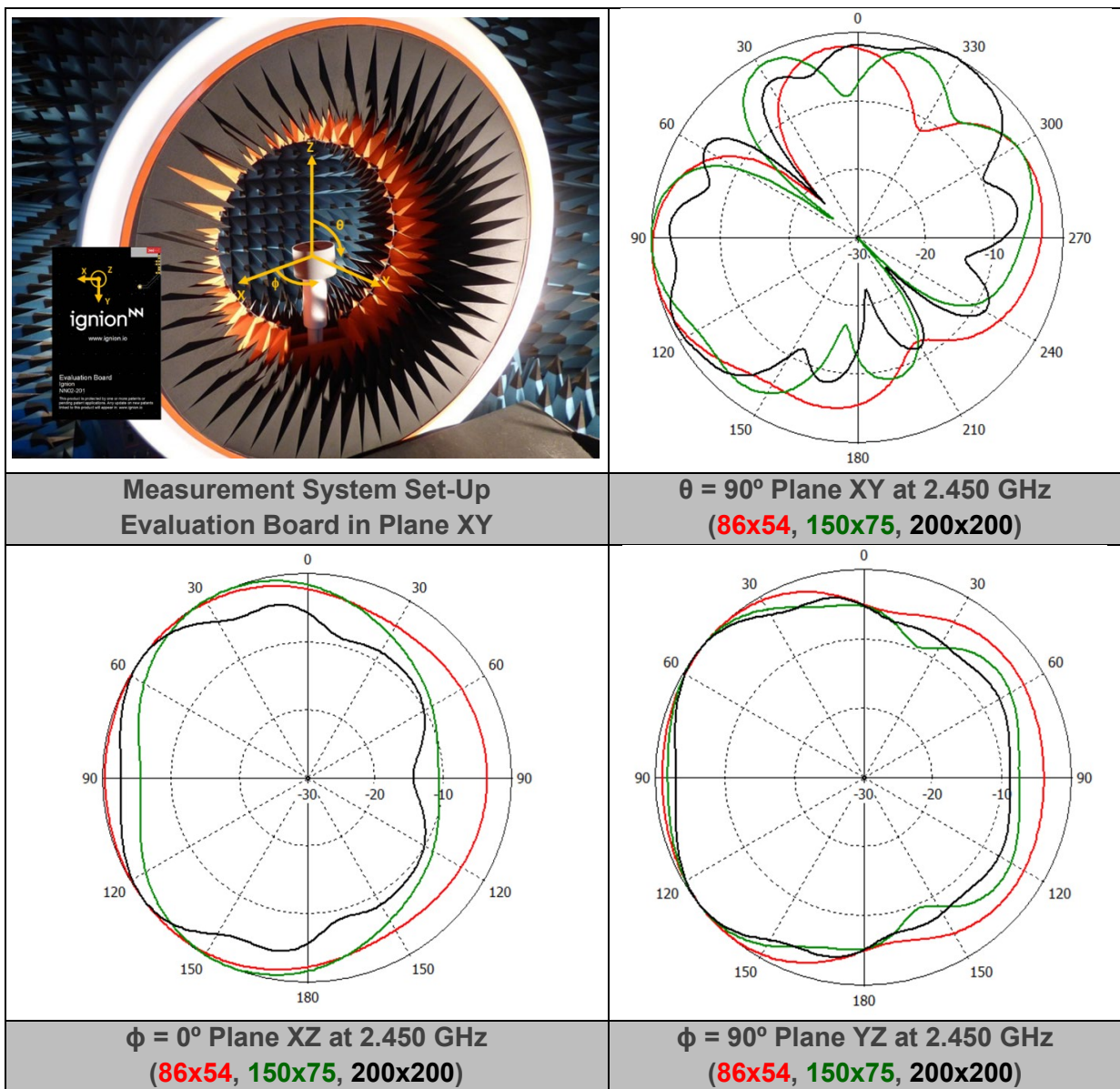

<sup>2</sup> See terms and conditions for a free Antenna Intelligence Cloud service in 24h at: <https://www.ignion.io/antenna-intelligence/>



LFR Wi-Fi 6E 2.400-2.500 GHz	Gain	Peak Gain <small>(86x54)</small>	3.2 dBi
		Average Gain across the band <small>(86x54)</small>	3.2 dBi
		Gain Range across the band (min, max) <small>(86x54)</small>	3.1 <--> 3.2 dBi
	Efficiency	Peak Efficiency <small>(86x54)</small>	85.9 %
		Average Efficiency across the band <small>(86x54)</small>	84.9 %
		Efficiency Range across the band (min, max) <small>(86x54)</small>	83.0 – 85.9 %

**Table 8** - Antenna gain and total efficiency from the Evaluation Board of 86mm x 54mm (Figure 5) for 2.400GHz – 2.500GHz with the matching network of Figure 7. Simulated results obtained with CST.

LFR Wi-Fi 6E 2.400- 2.500 GHz	Gain	Peak Gain <small>(150x75)</small>	4.1 dBi
		Average Gain across the band <small>(150x75)</small>	4.0 dBi
		Gain Range across the band (min, max) <small>(150x75)</small>	3.8 <--> 4.1 dBi
	Efficiency	Peak Efficiency <small>(150x75)</small>	81.1 %
		Average Efficiency across the band <small>(150x75)</small>	78.9 %
		Efficiency Range across the band (min, max) <small>(150x75)</small>	77.2 – 81.1 %

**Table 9** - Antenna gain and total efficiency from the Evaluation Board of 150mm x 75mm (Figure 5) for 2.400GHz – 2.500GHz with the matching network of Figure 8. Simulated results obtained with CST.

LFR Wi-Fi 6E 2.400- 2.500 GHz	Gain	Peak Gain <small>(200x200)</small>	5.2 dBi
		Average Gain across the band <small>(200x200)</small>	5.1 dBi
		Gain Range across the band (min, max) <small>(200x200)</small>	4.8 <--> 5.2 dBi
	Efficiency	Peak Efficiency <small>(200x200)</small>	84.6 %
		Average Efficiency across the band <small>(200x200)</small>	81.8 %
		Efficiency Range across the band (min, max) <small>(200x200)</small>	77.6 – 84.6 %

**Table 10** – Antenna gain and total efficiency from the Evaluation Board of 200 mm x 200 mm (Figure 5) for 2.400 GHz – 2.500 GHz with the matching network of Figure 7. Simulated results obtained with CST.

### 3.5. RADIATION PATTERNS (5.170 - 5.835 GHz), GAIN, AND EFFICIENCY

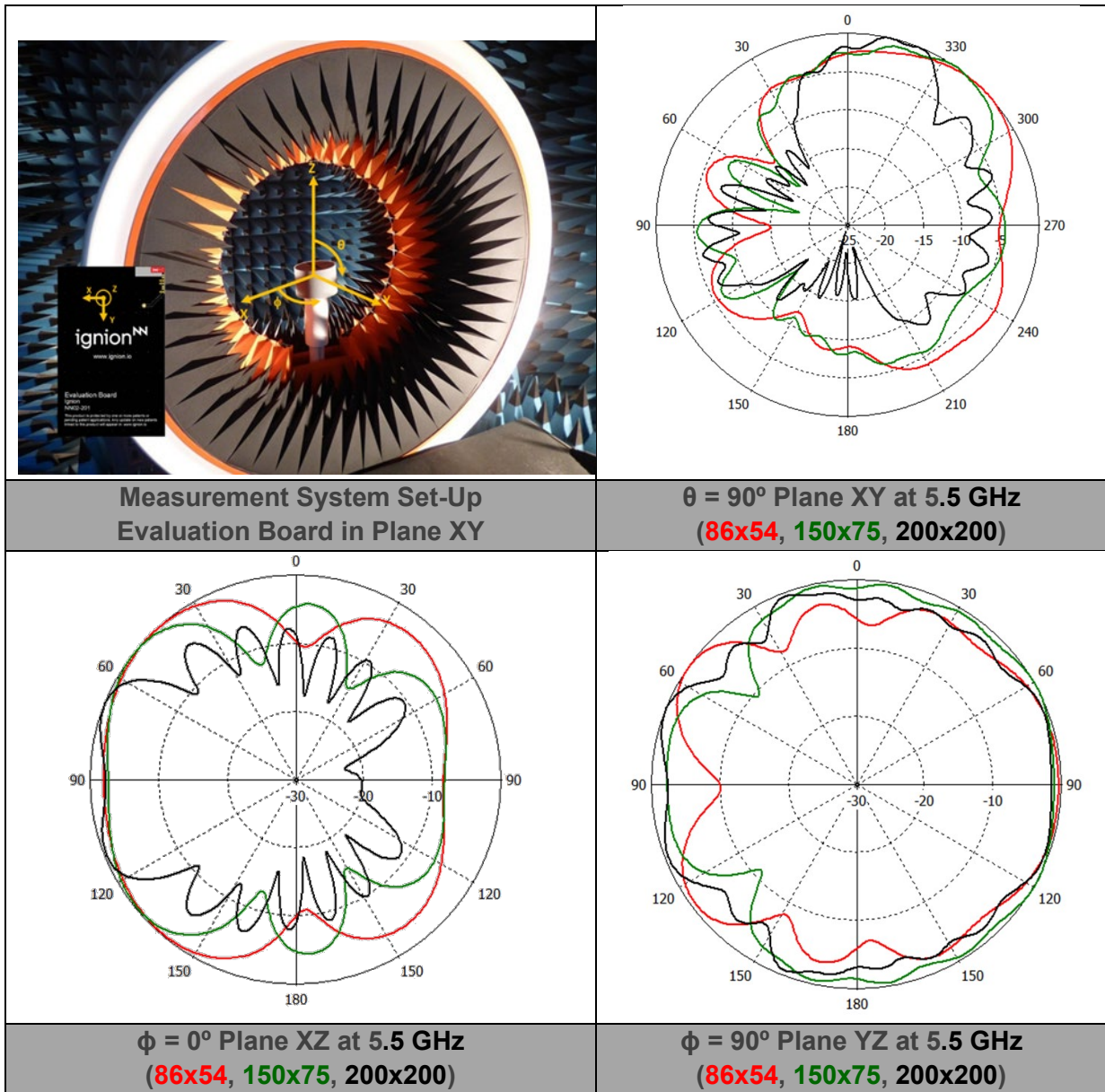

<b>HFR Wi-Fi 6E 5.170-5.835 GHz</b>	<b>Gain</b>	<b>Peak Gain</b> <small>(86x54)</small>	<b>3.3</b>
		<b>Average Gain across the band</b> <small>(86x54)</small>	<b>3.1</b>
		<b>Gain Range across the band (min, max)</b> <small>(86x54)</small>	<b>2.9 – 3.3</b>
	<b>Efficiency</b>	<b>Peak Efficiency</b> <small>(86x54)</small>	<b>88.8</b>
		<b>Average Efficiency across the band</b> <small>(86x54)</small>	<b>87.3</b>
		<b>Efficiency Range across the band (min, max)</b> <small>(86x54)</small>	<b>85.8 – 88.8</b>

**Table 11** - Antenna gain and total efficiency from the Evaluation Board of 86 mm x 54 mm (Figure 5) for 5.170 GHz – 5.835 GHz with the matching network of Figure 7. Simulated results obtained with CST.

<b>HFR Wi-Fi 6E 5.170-5.835 GHz</b>	<b>Gain</b>	<b>Peak Gain</b> <small>(150x75)</small>	5.1
		<b>Average Gain across the band</b> <small>(150x75)</small>	5.0
		<b>Gain Range across the band (min, max)</b> <small>(150x75)</small>	4.7 – 5.1
	<b>Efficiency</b>	<b>Peak Efficiency</b> <small>(150x75)</small>	92.1
		<b>Average Efficiency across the band</b> <small>(150x75)</small>	91.6
		<b>Efficiency Range across the band (min, max)</b> <small>(150x75)</small>	90.7 – 92.1

**Table 12** - Antenna gain and total efficiency from the Evaluation Board of 150 mm x 75 mm (Figure 5) for 5.170 GHz – 5.835 GHz with the matching network of Figure 8. Simulated results obtained with CST.

<b>HFR Wi-Fi 6E 5.170-5.835 GHz</b>	<b>Gain</b>	<b>Peak Gain</b> <small>(200x200)</small>	7.8
		<b>Average Gain across the band</b> <small>(200x200)</small>	7.5
		<b>Gain Range across the band (min, max)</b> <small>(200x200)</small>	7.3 – 7.8
	<b>Efficiency</b>	<b>Peak Efficiency</b> <small>(200x200)</small>	91.3
		<b>Average Efficiency across the band</b> <small>(200x200)</small>	89.7
		<b>Efficiency Range across the band (min, max)</b> <small>(200x200)</small>	88.5 – 91.3

**Table 13** - Antenna gain and total efficiency from the Evaluation Board of 200 mm x 200 mm (Figure 5) for 5.170 GHz – 5.835 GHz with the matching network of Figure 7. Simulated results obtained with CST.

### 3.6. RADIATION PATTERNS (5.925 - 7.125 GHz), GAIN, AND EFFICIENCY

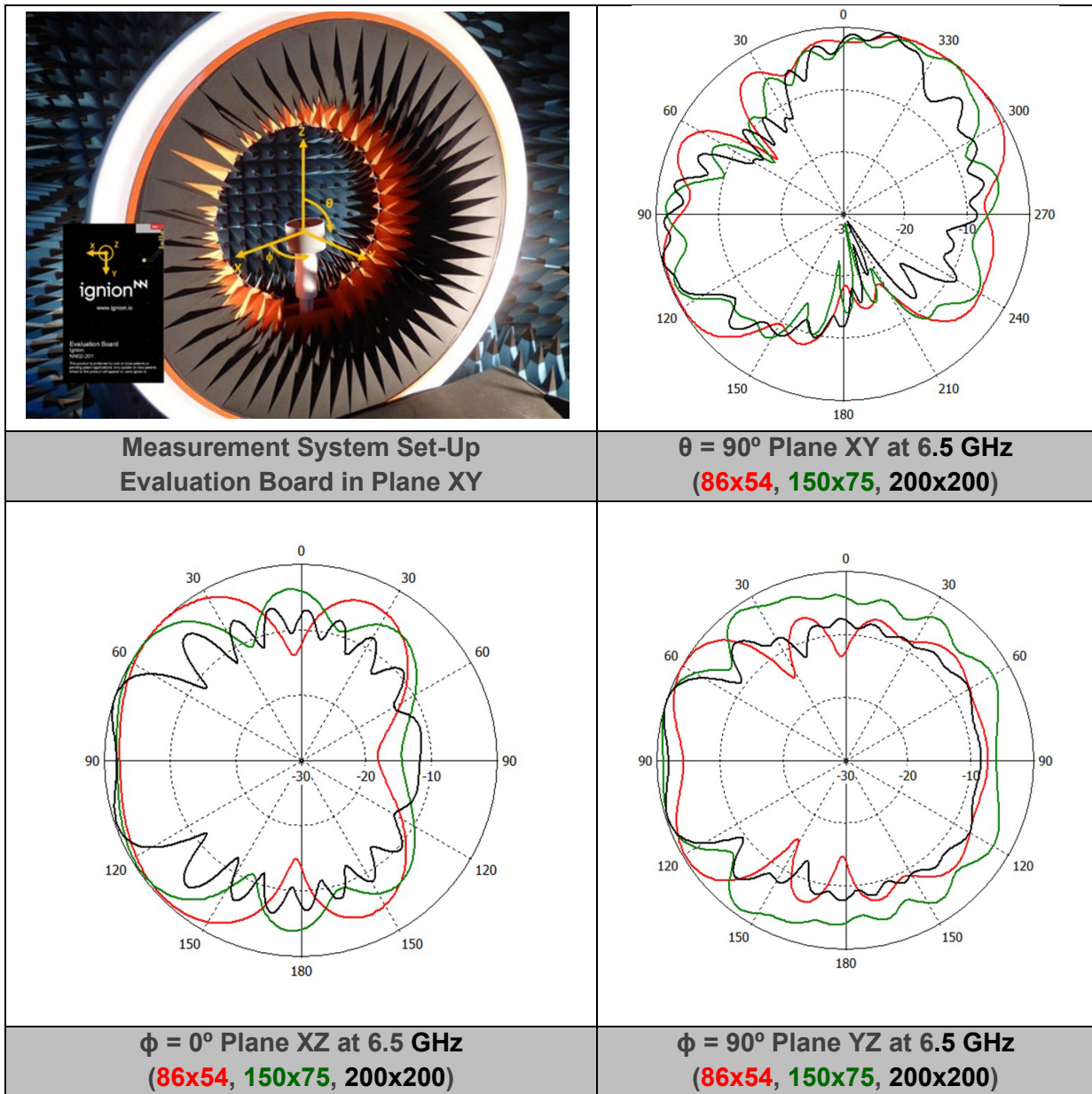

<b>HFR Wi-Fi 6E 5.925-7.125 GHz</b>	<b>Gain</b>	<b>Peak Gain</b> <small>(86x54)</small>	5.0
		<b>Average Gain across the band</b> <small>(86x54)</small>	4.3
		<b>Gain Range across the band (min, max)</b> <small>(86x54)</small>	2.9 – 5.0
	<b>Efficiency</b>	<b>Peak Efficiency</b> <small>(86x54)</small>	92.2
		<b>Average Efficiency across the band</b> <small>(86x54)</small>	89.6
		<b>Efficiency Range across the band (min, max)</b> <small>(86x54)</small>	85.8 – 92.2

**Table 14** - Antenna gain and total efficiency from the Evaluation Board of 86 mm x 54 mm (Figure 5) for 5.925 GHz – 7.125 GHz with the matching network of Figure 7. Simulated results obtained with CST.

<b>HFR Wi-Fi 6E 5.925-7.125 GHz</b>	<b>Gain</b>	<b>Peak Gain</b> <small>(150x75)</small>	4.8
		<b>Average Gain across the band</b> <small>(150x75)</small>	4.5
		<b>Gain Range across the band (min, max)</b> <small>(150x75)</small>	4.2 – 4.8
	<b>Efficiency</b>	<b>Peak Efficiency</b> <small>(150x75)</small>	91.5
		<b>Average Efficiency across the band</b> <small>(150x75)</small>	88.7
		<b>Efficiency Range across the band (min, max)</b> <small>(150x75)</small>	80.5 – 91.5

**Table 15** - Antenna gain and total efficiency from the Evaluation Board of 150 mm x 75 mm (Figure 5) for 5.925 GHz – 7.125 GHz with the matching network of Figure 8. Simulated results obtained with CST.

<b>HFR Wi-Fi 6E 5.925-7.125 GHz</b>	<b>Gain</b>	<b>Peak Gain</b> <small>(200x200)</small>	7.3
		<b>Average Gain across the band</b> <small>(200x200)</small>	6.7
		<b>Gain Range across the band (min, max)</b> <small>(200x200)</small>	6.5 – 7.3
	<b>Efficiency</b>	<b>Peak Efficiency</b> <small>(200x200)</small>	90.9
		<b>Average Efficiency across the band</b> <small>(200x200)</small>	89.0
		<b>Efficiency Range across the band (min, max)</b> <small>(200x200)</small>	79.3 – 90.9

**Table 16** – Antenna gain and total efficiency from the Evaluation Board of 200 mm x 200 mm (Figure 5) for 5.925 GHz – 7.125 GHz with the matching network of Figure 7. Simulated results obtained with CST.

**Do you need more help choosing the right antenna for your device?**

Use our **Antenna Intelligence Cloud service** and get your ready-to-test antenna design specifically for your platform **free of charge**<sup>1</sup> and in **24 hours**.

<https://www.ignion.io/antenna-intelligence/>

This product is protected by at least one of the following [patents](#) PAT. US 10,601,110 B2, and other domestic and international patents pending. Any update on new patents linked to this product will appear in <https://ignion.io/virtual-antenna/>.

All information contained within this document is the property of Ignion and is subject to change without prior notice. Information is provided “as is” and without warranties. It is prohibited to copy or reproduce this information without prior approval.

Ignion is an ISO 9001:2015 certified company. All our antennas are lead-free and RoHS and REACH compliant.

ISO 9001: 2015 Certified



ignion<sup>™</sup>

Your innovation.  
Accelerated.

Contact:  
[support@ignion.io](mailto:support@ignion.io)  
+34 935 660 710

#### Barcelona

Av. Alcalde Barnils, 64-68 Modul C, 3a pl.  
Sant Cugat del Vallés  
08174 Barcelona  
Spain

#### Shanghai

Shanghai Bund Centre  
18/F Bund Centre, 222 Yan'an Road East,  
Huangpu District  
Shanghai, 200002  
China

#### Tampa

8875 Hidden River Parkway  
Suite 300  
Tampa, FL 33637  
USA